



# UNG65-12 (12V65Ah/20hr)



UNG Series is GEL battery which is manufactured with AGM separator and colloidal Silicon. Gel battery are featured with low self-discharge, strong ability to recover from deep discharging, excellent cycle life and performance at cold ambient temperatures than conventional VRLA

## Battery Construction

Component	Positive plate	Negative plate	Container	Cover	Safety valve	Terminal	Separator	Electrolyte
Raw material	Lead dioxide	Lead	ABS	ABS	Rubber	Copper	Fiberglass	Colloidal silicon

## General Feature

- Micro millimeter SiO<sub>2</sub> and H<sub>2</sub>SO<sub>4</sub> technology for Efficient gas recombination of up to 99% and Freedom from electrolyte maintenance or water adding.
- Not restricted for air transport-complies with IATA/ICAO Special Provision A67.
- UL-recognized component.
- Can be mounted in any orientation.
- Computer designed lead, calcium tin alloy grid for high power density.
- Long service life, float or cyclic applications.
- Maintenance-free operation.
- Low self discharge.

## SPECIFICATION

Nominal voltage ..... 12V  
 Number of cell ..... 6  
 Length(mm/inch) ..... 350/13.8  
 Width(mm/inch) ..... 167/6.57  
 Height(mm/inch) ..... 179/7.05  
 Total Height(mm/inch) ..... 179/7.05  
 Approx. Weight(kg/lbs) ..... 20/44.1

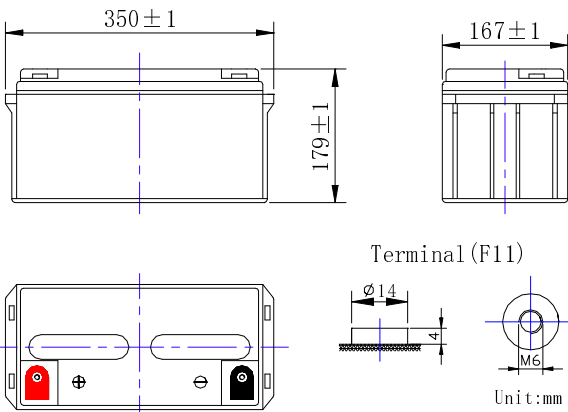

## Performance Characteristics

Capacity 77°F(25°C)	100 hour rate (0.78A、 11.1V)	78Ah
	20 hour rate (3.25A、 10.8V)	65Ah
	10 hour rate (6.3A、 10.5V)	63Ah
	1 hour rate (38.7A、 9.6V)	38.7Ah
Internal Resistance	Full charged Battery77°F(25°C):9mΩ	
Operating Temperature Range	Discharge: -20~60°C	
	Charge: -10~60°C	
	Storage: -20~60°C	
Self-Discharge 3% of capacity declined per month at 20°C(average)		
Max. discharge current77°F(25°C): 650A(5S)		
Charge (Constant Voltage)	Float: 13.38~13.68 V/77° F(25°C)	
	Cycle:14.28~14.52 V/77°F/(25°C) Max. Current: 16.3A	

Discharge Constant Current (Amperes at 77° F25 °C)

End Point Volts/Cell	5min	10min	15min	30min	1h	3h	5h	10h	20h
1.60V	204	148	118	66.2	38.7	16.6	11.6	6.60	3.45
1.65V	194	143	113	64.2	37.5	16.4	11.4	6.50	3.45
1.70V	182	136	107	61.5	36.1	16.1	11.2	6.40	3.40
1.75V	169	127	101	58.6	34.3	15.8	11.0	6.30	3.35
1.80V	156	115	93.8	55.0	32.2	15.4	10.8	6.10	3.25

Discharge Constant Power (watts at 77° F 25 °C)

End Point Volts/Cell	5min	10min	15min	30min	45min	1h	2h	3h	5h
1.60V	340	226	178	120	94.8	75.2	48.8	34.1	22.8
1.65V	318	213	168	114	90.4	71.9	47.3	33.3	22.4
1.70V	298	200	158	107	85.8	68.7	45.8	32.3	21.9
1.75V	276	187	148	101	81.2	65.3	43.9	31.4	21.5
1.80V	256	174	139	94.7	76.5	61.7	42.0	30.3	20.9

(Note)The above characteristics data are average values obtained Within three charge/discharge cycles not the minimum values.

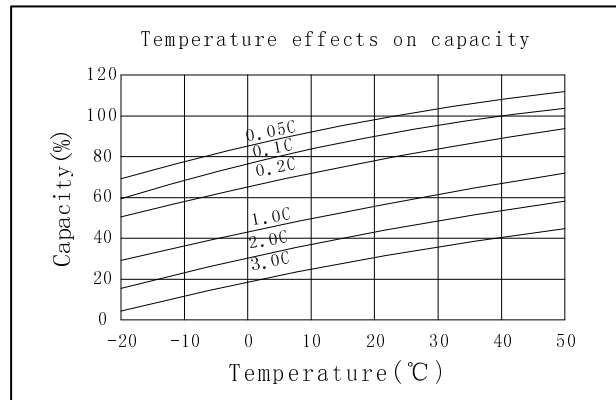
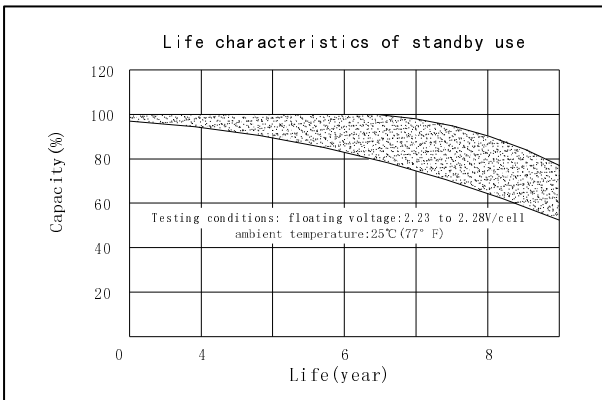
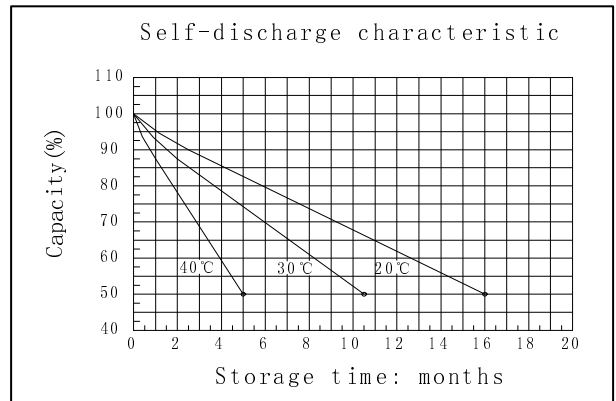
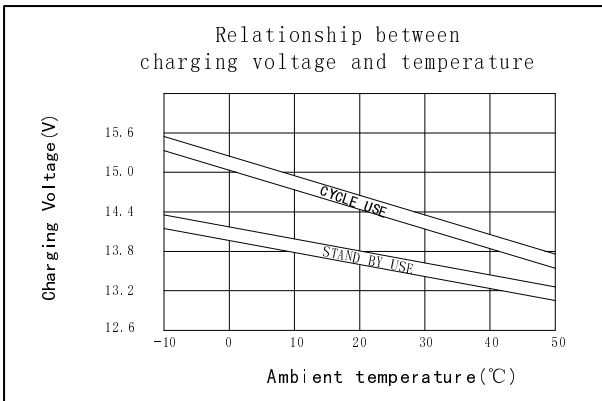
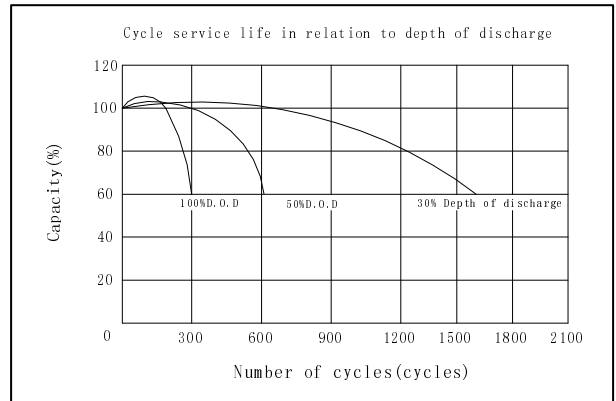
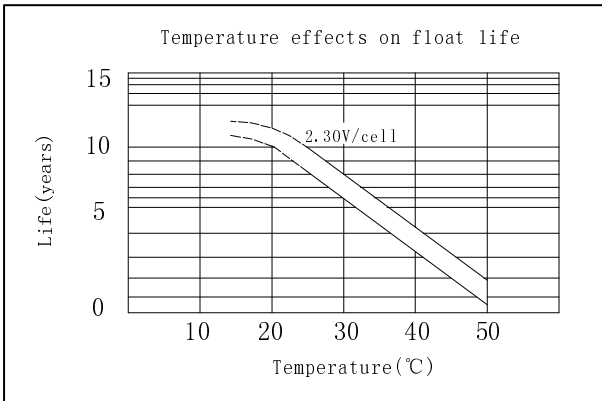
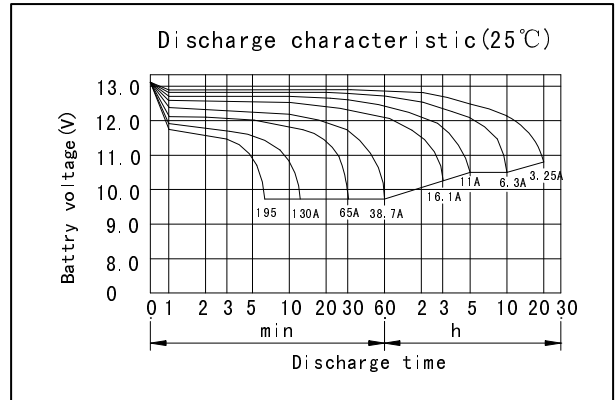
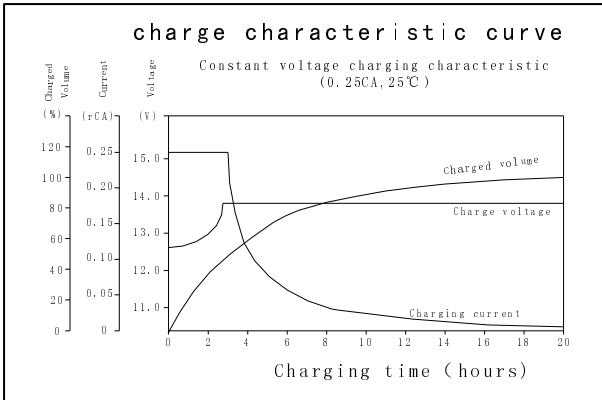

**OREMA POWER CO., LTD**

Add: Datang Industry Park Xinfeng Ganzhou City, Jiangxi Province, China

TEL: +86-0797-2299669 +86-0797-2299553

FAX: +86-0797-2299553



[www.oremabattery.com](http://www.oremabattery.com)