

General Features

- Positive and negative plates in lead-calcium tin alloy.
- Superior energy density
- Operates at a low internal pressure.
- Gas Recombination.
- Usable in any orientation.
- A recognized component of UL.
- Very high power output.
- Application specific designs.
- Six months shelf life at 20°C.
- Design life 10 years.



Dimensions

	Length	Width	Height	Total Height	Approx.Weight
<i>SI Units</i>	328mm	171mm	214mm	218mm	31Kg
<i>English Units</i>	12.91inch	6.73inch	8.43inch	8.58inch	68.3lbs

Performance Characteristics

- Nominal Voltage: 12V
- Number of cell: 6
- Nominal Capacity 77° F(25°C): 15 min Wattage @1.67V 380W/cell
- Nominal Capacity 77° F(25°C): 10 hour rate (9.8A, 10.8V) 98Ah
- Internal Resistance: Fully Charged battery 68° F(20°C) 4.8mΩ
- Self-Discharge: 3% of capacity declined per month at 20°C
- Operating Temperature Range: Discharge -20~60°C Charge -10~60°C Storage -20~60°C
- Max. Discharge Current 68° F(20°C): 1000A (5S)
- Short Circuit Current: 2100A
- Charge Methods: Constant Voltage Charge 68° F(20°C)
 - Cycle use: 14.4 ~ 14.7V Maximum charging current 25A
 - Standby use: 13.6 ~ 13.8V

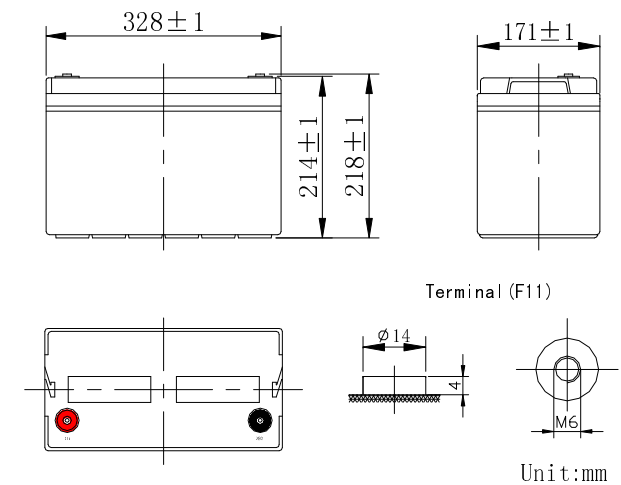



UNH12-380W

Rechargeable Products Sealed Lead Acid Battery

Discharge Data

Constant Current Discharge Data(Amperes at 25°C)																							
End Voltage Per cell/V	10min	15min	20min	25min	30min	35min	40min	45min	50min	55min	1h	1.5h	2h	2.5h	3h	4h	5h	6h	7h	8h	9h	10h	20h
1.60	283.0	220.0	175.0	145.0	125.0	110.0	97.5	91.0	83.0	78.2	75.0	52.7	39.6	33.3	29.1	23.0	19.5	16.5	14.2	12.6	11.3	10.3	5.45
1.65	270.0	210.0	168.0	139.0	122.0	106.5	95.0	88.5	81.0	76.7	73.5	52.1	38.9	32.7	28.6	22.5	19.1	16.2	13.9	12.4	11.2	10.2	5.40
1.70	255.0	198.0	159.0	133.0	118.0	103.0	92.0	86.0	79.0	75.0	72.0	51.4	38.0	32.0	28.0	22.0	18.7	15.8	13.6	12.2	11.0	10.1	5.35
1.75	240.0	186.0	150.0	127.0	114.0	99.5	89.0	83.5	77.0	73.3	70.5	50.7	37.1	31.3	27.4	21.5	18.3	15.4	13.3	12.0	10.8	10.0	5.30
1.80	223.0	173.0	141.0	120.0	109.0	95.0	85.5	80.5	74.5	71.3	68.8	50.0	36.0	30.4	26.8	20.9	17.8	15.0	12.9	11.7	10.6	9.80	5.20

Constant Power Discharge Data(Watts per cell at 25°C)																							
End Voltage Per cell/V	10min	15min	20min	25min	30min	35min	40min	45min	50min	55min	1h	1.5h	2h	2.5h	3h	4h	5h	6h	7h	8h	9h	10h	12h
1.60	471.0	388.0	310.0	262.0	231.0	200.0	181.0	168.0	150.0	137.0	128.0	90.5	71.0	59.0	52.3	41.5	35.5	30.9	27.2	24.3	22.4	20.6	17.2
1.65	455.0	383.0	300.0	253.0	223.0	194.0	176.0	162.0	146.0	134.5	126.0	88.5	69.6	58.0	51.4	40.8	34.8	30.3	26.7	24.0	22.1	20.4	17.1
1.67	445.0	380.0	295.0	248.0	220.0	191.0	173.0	160.0	144.0	133.0	125.0	87.5	69.0	57.5	51.0	40.5	34.5	30.0	26.5	23.8	22.0	20.3	17.0
1.70	432.0	370.0	289.0	243.0	215.0	187.0	170.0	157.0	142.0	131.0	123.0	86.5	68.1	56.9	50.5	40.0	34.1	29.7	26.2	23.6	21.8	20.2	16.9
1.75	424.0	358.0	278.0	233.0	207.0	180.0	164.0	152.0	138.0	127.5	120.0	84.5	66.6	55.8	49.6	39.2	33.4	29.1	25.7	23.2	21.5	20.0	16.8
1.80	396.0	342.0	266.0	222.0	197.0	172.0	158.0	145.0	133.0	123.5	116.0	81.5	64.8	54.5	48.5	38.2	32.7	28.5	25.2	22.8	21.1	19.7	16.5

