



UN120-12H 12V120Ah

Rechargeable Products Sealed Lead Acid Battery

www.oremabattery.com

General Features

- Positive and negative plates in lead-calcium tin alloy.
- Superior energy density
- Operates at a low internal pressure.
- Gas Recombination.
- Low Self Discharge.
- Long Service Life.
- A recognized component of UL.
- Application specific designs.
- Six months shelf life at 20°C.
- Design life 10 years.



Dimensions

	Length	Width	Height	Total Height	Approx. Weight
<i>SI Units</i>	410mm	176mm	227mm	227mm	35.5Kg
<i>English Units</i>	16.1inch	6.93inch	8.94inch	8.94inch	78.24lbs

Performance Characteristics

- Nominal Voltage: 12V
- Number of cell: 6
- Nominal Capacity 77° F(25°C): 10 hour rate (12.2A, 10.8V) 122Ah
1 hour rate (87A, 9.6V) 87Ah
- Internal Resistance: Fully Charged battery 77° F(25°C) 4.5mΩ
- Self-Discharge: 3% of capacity declined per month at 20°C
- Operating Temperature Range: Discharge -20~60°C Charge -10~60°C Storage -20~60°C
- Max. Discharge Current 77° F(25°C): 950A (5S)
- Short Circuit Current: 2300A
- Charge Methods: Constant Voltage Charge 77° F(25°C)
Cycle use: 14.4 ~ 14.7V Maximum charging current 30A
Standby use: 13.6 ~ 13.8V

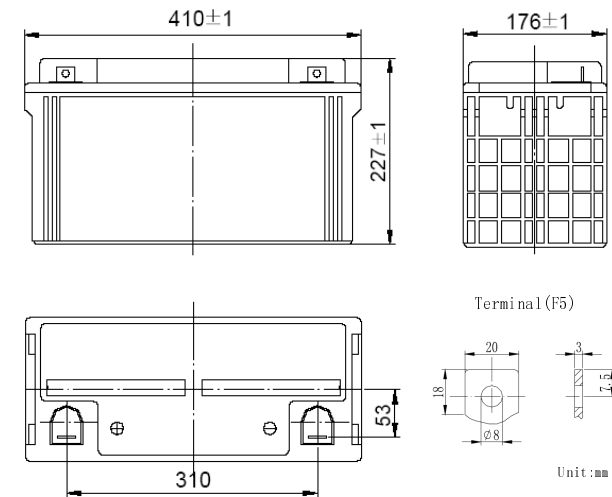



UN120-12H 12V120Ah

Rechargeable Products Sealed Lead Acid Battery

Discharge Data

Constant Current Discharge Data(Amperes at 25°C)

End Voltage Per cell/V	10min	15min	20min	25min	30min	35min	40min	45min	50min	55min	1h	1.5h	2h	2.5h	3h	4h	5h	6h	7h	8h	9h	10h	20h
1.60	305.0	235.0	195.0	165.0	145.0	130.0	118.0	107.0	98.0	92.0	87.0	63.5	49.5	40.5	34.5	26.8	22.1	19.1	16.8	15.2	14.1	13.0	6.65
1.65	290.0	225.0	187.0	159.0	140.0	126.0	114.7	104.2	95.5	89.7	84.8	61.7	47.9	39.2	33.4	26.0	21.5	18.6	16.4	14.9	13.9	12.9	6.60
1.70	274.0	214.0	178.0	152.0	134.0	122.0	111.2	101.2	92.8	87.2	82.4	59.8	46.2	37.8	32.2	25.1	20.8	18.0	15.9	14.5	13.6	12.7	6.55
1.75	257.0	203.0	169.0	145.0	128.0	117.0	107.4	97.8	89.9	84.4	79.8	57.7	44.4	36.4	31.0	24.2	20.1	17.4	15.4	14.1	13.3	12.5	6.50
1.80	239.0	190.0	159.0	137.0	121.0	111.0	103.1	94.0	86.5	81.3	77.0	55.4	42.5	34.9	29.7	23.2	19.3	16.7	14.8	13.6	12.9	12.2	6.40

Constant Power Discharge Data(Watts per cell at 25°C)

End Voltage Per cell/V	10min	15min	20min	25min	30min	35min	40min	45min	50min	55min	1h	1.5h	2h	2.5h	3h	4h	5h	6h	7h	8h	9h	10h	12h
1.60	520.0	435.0	365.0	312.0	275.0	245.0	223.0	203.0	188.0	175.0	165.0	120.0	95.2	80.5	70.6	55.6	46.6	40.3	35.8	32.4	29.8	27.7	24.1
1.65	500.0	421.0	354.0	303.0	267.0	238.0	216.0	197.0	182.0	170.0	161.0	117.0	92.7	78.5	68.9	54.3	45.6	39.5	35.2	31.9	29.4	27.3	23.9
1.70	478.0	406.0	342.0	293.0	258.0	230.0	209.0	190.0	176.0	165.0	156.0	114.0	90.2	76.4	67.1	52.9	44.5	38.6	34.5	31.3	28.9	26.9	23.6
1.75	455.0	390.0	329.0	283.0	249.0	222.0	202.0	183.0	170.0	159.0	151.0	110.0	87.7	74.3	65.3	51.5	43.4	37.7	33.8	30.7	28.4	26.4	23.3
1.80	430.0	372.0	315.0	272.0	239.0	213.0	194.0	176.0	163.0	153.0	146.0	106.0	85.2	72.1	63.4	50.0	42.2	36.7	33.0	30.0	27.8	25.9	22.9

